

セッティング記録 / SETUP RECORD

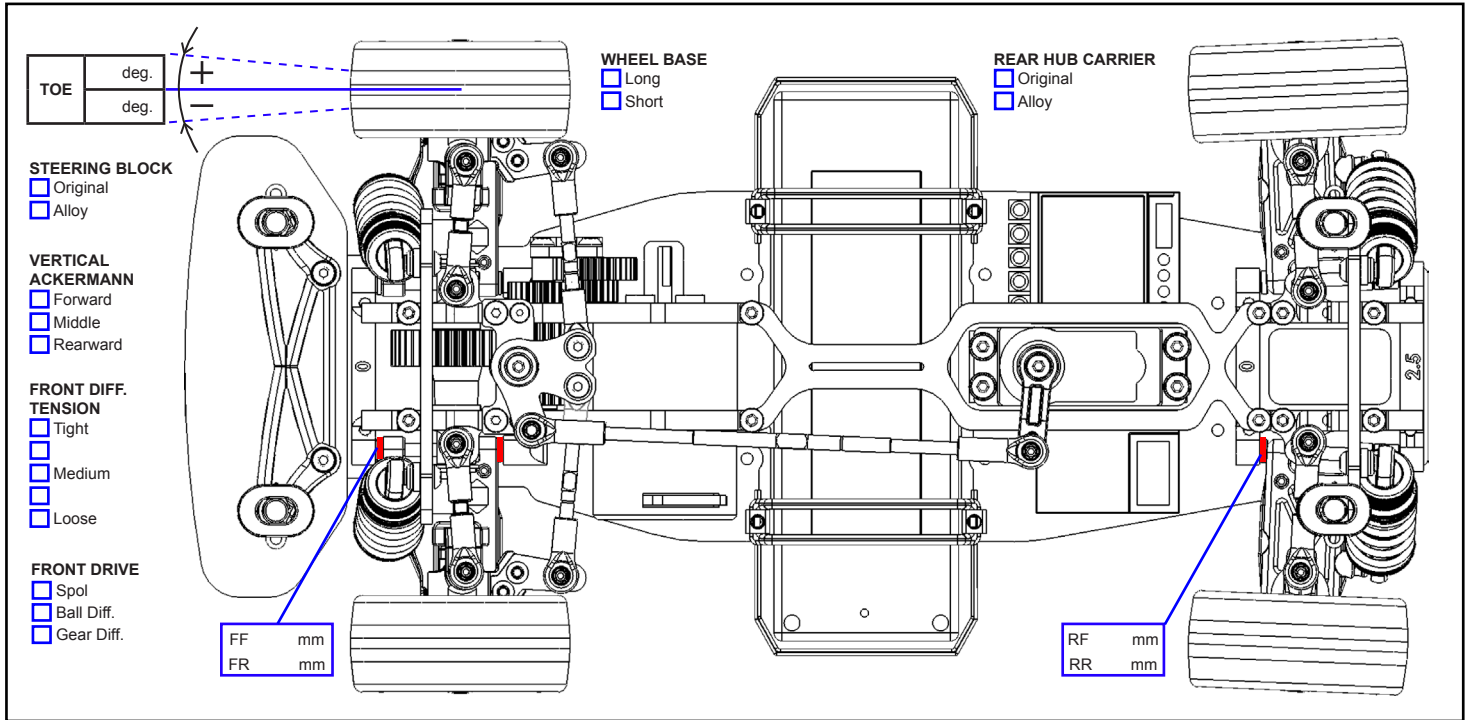

名前: _____ 日付: _____ トラック: _____
 Name: _____ Date: _____ Track: _____
 国籍: _____ 条件: _____ 温度: _____
 Country: _____ Condition: _____ Temperature: _____



FRONT MEASUREMENTS		FRONT SHOCKS	
RIDE HEIGHT	mm	OIL WEIGHT	wt
CAMBER ANGLE	deg	PISTON <input type="checkbox"/> Opt. <input type="checkbox"/> 1.0mm <input type="checkbox"/> 2hole	
WHEEL HUBS	mm	<input type="checkbox"/> Std. <input type="checkbox"/> 1.2mm <input type="checkbox"/> 3hole	
WHEEL SPACER	mm	BLADDER	
NOTES:		SPRING	

REAR MEASUREMENTS		REAR SHOCKS	
RIDE HEIGHT	mm	OIL WEIGHT	wt
CAMBER ANGLE	deg	PISTON <input type="checkbox"/> Opt. <input type="checkbox"/> 1.0mm <input type="checkbox"/> 2hole	
WHEEL HUBS	mm	<input type="checkbox"/> Std. <input type="checkbox"/> 1.2mm <input type="checkbox"/> 3hole	
WHEEL SPACER	mm	BLADDER	
NOTES:		SPRING	

MOTOR	
PINION GEAR	
BATTERY	
BODY SHELLS	
WING	
ESC SETTING	
NOTES:	

	FRONT	REAR
BRAND		
COMPOUND		
INSERT		
WHEEL		
TIRE TREATMENT		

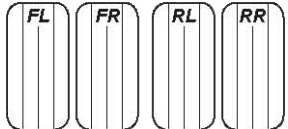

NOTES:

